

# K140B AMBIENT TEMPERATURE CONTROLLER



This kit is designed to switch heaters and coolers on and off to maintain a preset temperature making it ideal for things like brewing, incubating and yoghurt making.

## NOTE:

MAKE SURE YOU READ AND UNDERSTAND THESE NOTES FULLY BEFORE STARTING CONSTRUCTION.

## OPTIONS

To set up K140B as a switch-mode controller for peltier devices etc. R7 is 22K and R6 is not fitted. For thermostat type use with fridge compressors and heaters R6 is 10M and R8 is not fitted. Link "C" to "A" for heating or "B" to "A" for cooling.

## CONSTRUCTION

Construction is simple as there are few components. Start with the lowest profile components like resistors and diodes and finish with the tallest, such as screw terminals and electrolytic capacitors etc.

This kit can be set up for two modes of operation:

1. A continuously switching controller where the duty cycle varies according to the temperature differential. This mode of operation is desirable when driving Peltier devices and can also be used with resistive heaters.
2. An occasional switching controller with hysteresis, as typically used with refrigerators and air conditioners.

## CIRCUIT DESCRIPTION

IC2 regulates the incoming supply voltage down to 8V. The thermistor used has a nominal resistance of 100K +/- 1% ohms at 25deg.C. Therefore at 25deg. C the voltage at the + input of IC1:B would be +4V: determined by the voltage divider made up by R1 and the thermistor. In order for the same voltage to be present at the junction of R2 and VR1 the potentiometer would have to be centered: Set to 1Kohm. Therefore when the potentiometer is centered the temperature is set for 25deg. C. VR1 will adjust the set temperature between approximately 10 and 60 deg. C. If a lower set temperature is desirable, as would be the case

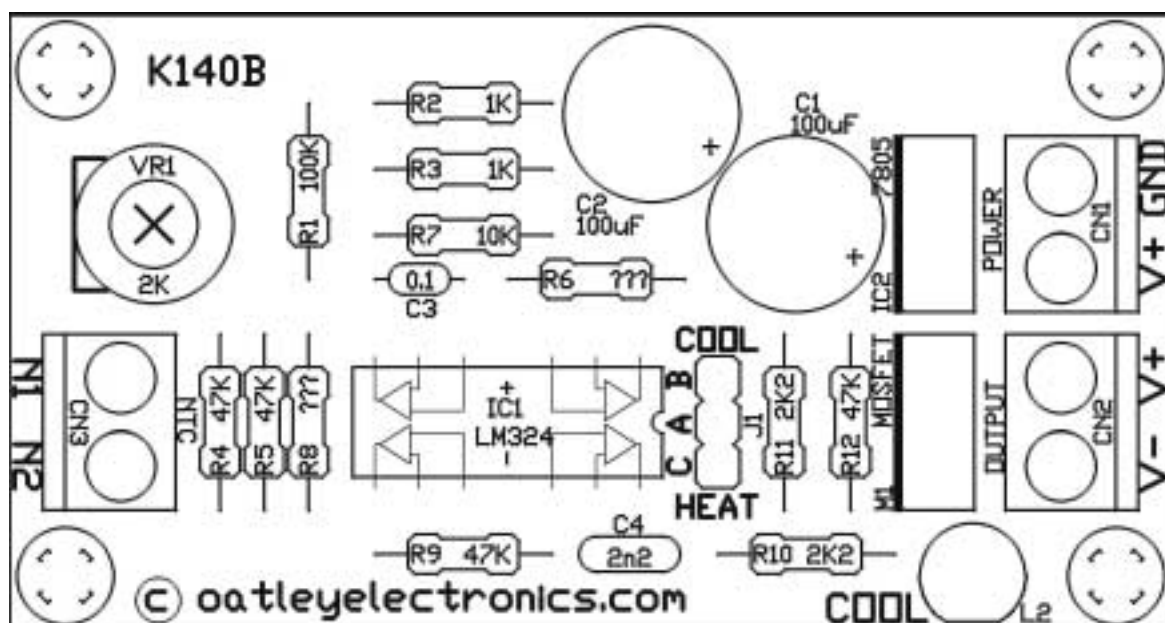

if controlling a refrigerator, the value of R2 should be reduced. For example reducing the value of R2 to 560 ohms would allow the set temperature to be reduced to 0deg. C. The following measurements of the thermistors resistance versus temperature could be used to draw a rough graph. 350Kohms at 0deg. C, 100Kohms at 25deg. C, 10Kohms at 100deg.C,

The voltage at the inverting input varies as the temperature varies. As the temperature rises the thermistor resistance falls and the voltage at the inverting input drops. IC1: C forms a sawtooth oscillator. The output of IC1:B and IC1:C are both connected to the inputs of IC1:A and D to drive the MOSFET M1. As the temperature falls below the preset level the output of IC1:A turns on or as the temperature rises the output of IC1:D turns on. Additional heatsinking may be required for Q4, depending on the load. The thermistor should be placed in contact with or near to the heated or cooled object to give the best performance and can be remotely connected by longer wires if needed.

#### **PARTS LIST**

##### **1/4W RESISTORS**

3 X 47K  
1 X 100K  
2 X 2K2  
2 X 1K  
2 X 10K  
1 X 10M  
1 X 22K

##### **SEMICONDUCTORS**

1 X MTP3055 MOSFET  
1 X 7808 / 7805 REGULATOR  
1 X LM324 OP-AMP  
1 X LED

##### **CAPACITORS**

2 X 100uF ELECTRO. CAP.  
1 X 0.1uF MONOLYTHIC CAP.

1 X 2n2 GREEN CAP

##### **MISC.**

1 X 100K NTC  
1 X IC SOCKET  
3 X 2 WAY TERMINAL  
1 X PCB LABELED K140B  
1 X 2K PCB MOUNT POT

SCHEMATIC DIAGRAM SUPPLIED WITH THE KIT